



**LUCAS**  
DISTRIBUTION, LLC

---

# INSTALLATION MANUAL

---

## PTL-3/5 PTL-5 Combination Lock System PTL-3R/5R

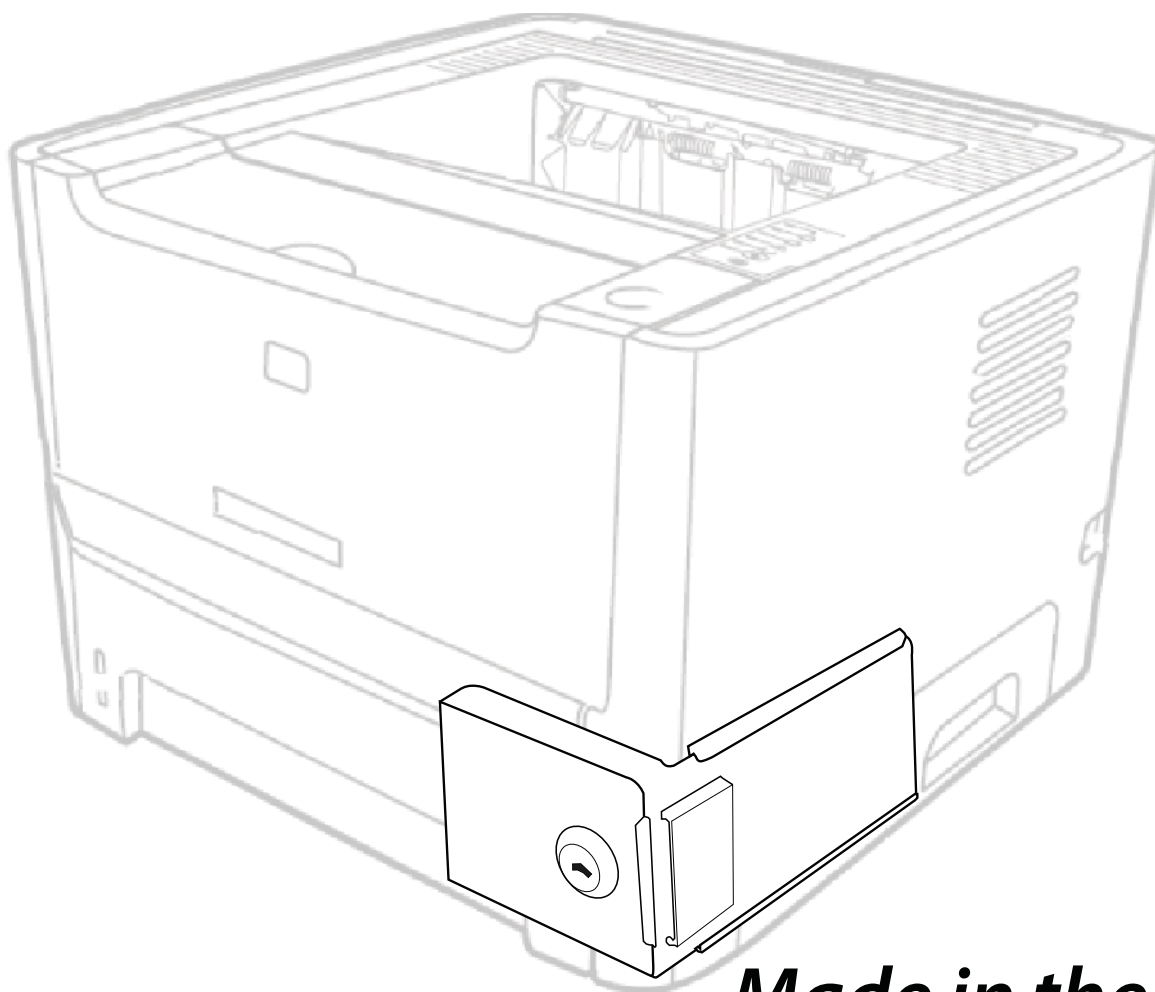

***Made in the USA!***

# Parts List

**For Technical Support:**  
**Email: sales@lucasdist.com**  
**Toll-Free: 866-232-4233**  
**Outside US: 770-554-5560**  
**www.lucasdist.com**

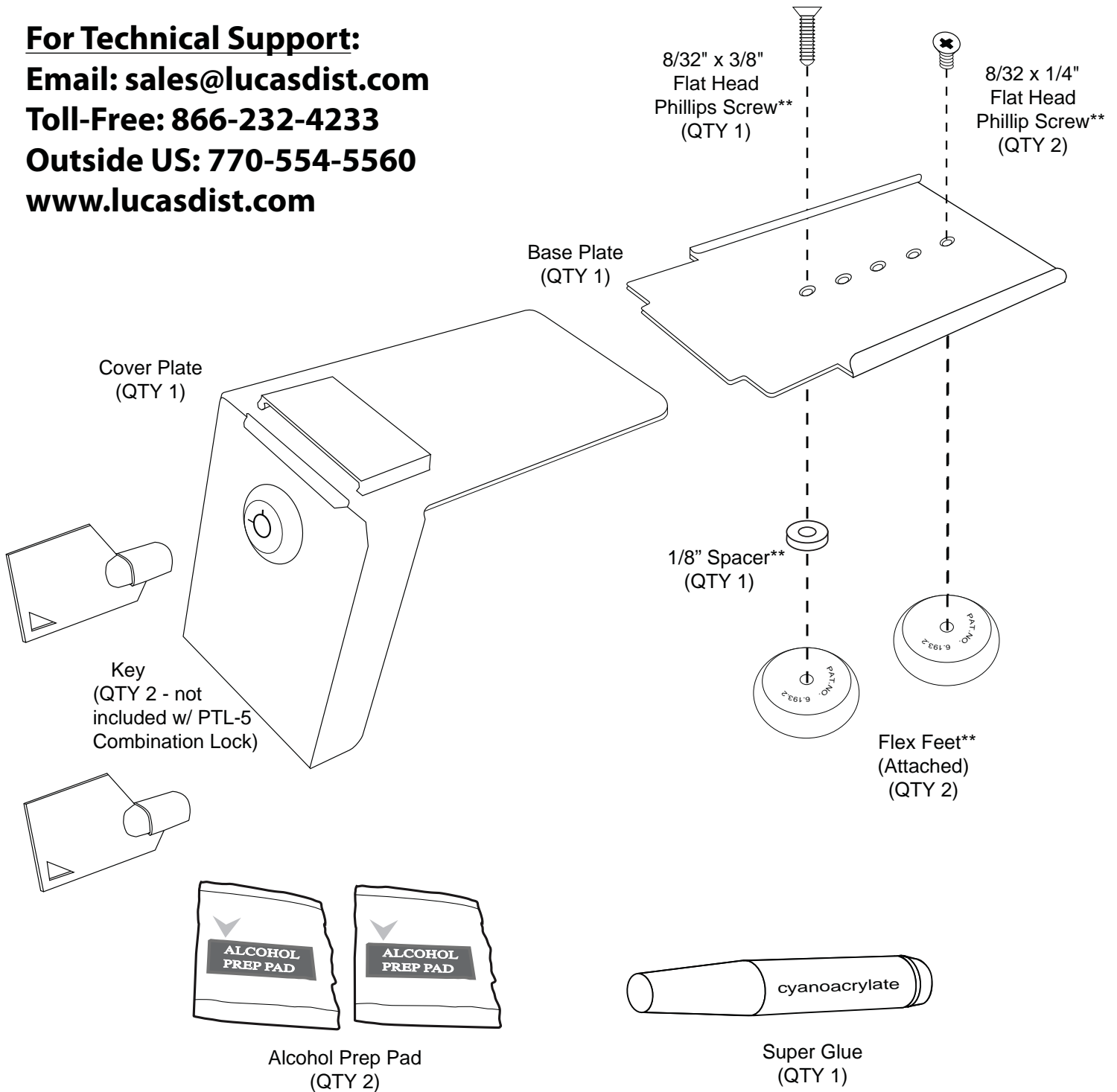

**\*\*Parts not included with PTL-3R/5R. 3/8" screw and spacer only used to help foot contact a curved surface.**

\*\*\*We highly recommend you visit our website at [www.lucasdist.com](http://www.lucasdist.com) and watch our short installation video\*\*\*

1. Position the PTL lock in different locations around the printer to determine best location.

The flex feet should make full contact with the printer. If the feet are not in full contact with the printer, loosen the screws on the base plate until feet sit flush with the mounting area. Make sure feet do not cover any vents, openings, or access panels.

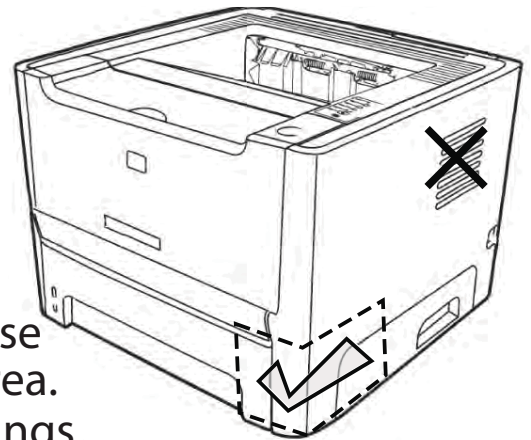

2. Trace around base plate to mark the installation area.

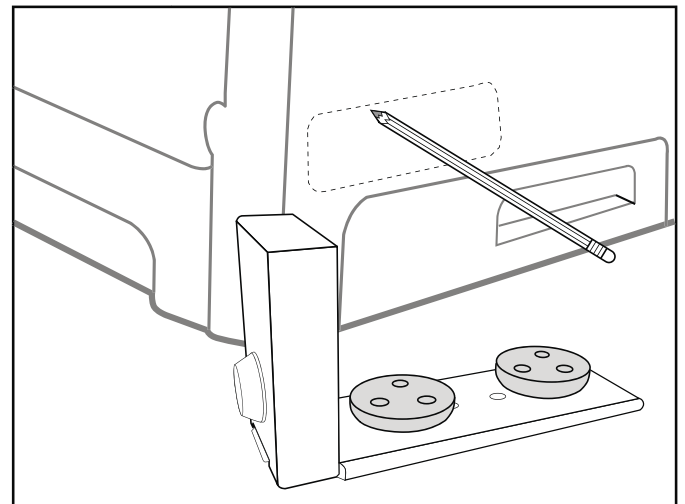

3. Use the provided alcohol wipes to **thoroughly** clean inside the marked area on the printer as well as the flex feet. (Clean entire surface of rubber on PTL-3R/5R.)

Allow all parts to air dry.

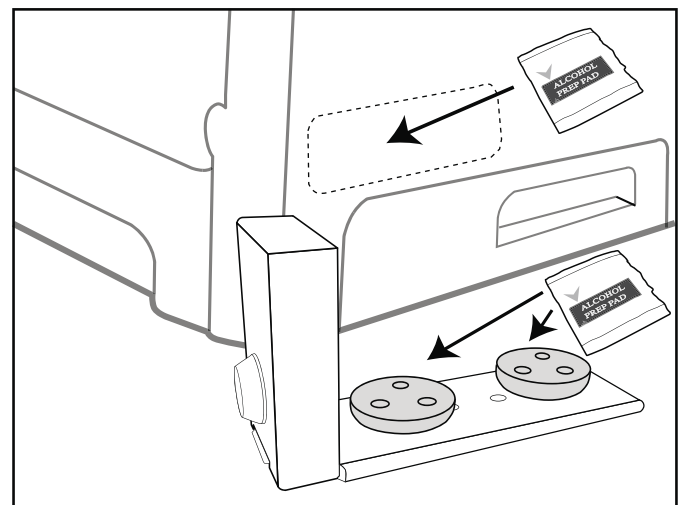

4. Place 7-8 drops of glue on each flex foot. Apply glue around the perimeter of each flex foot as well as in the middle of each flex foot. For the PTL-3R/5R, apply a bead of glue around the perimeter of the rubber as well as several beads running top to bottom.

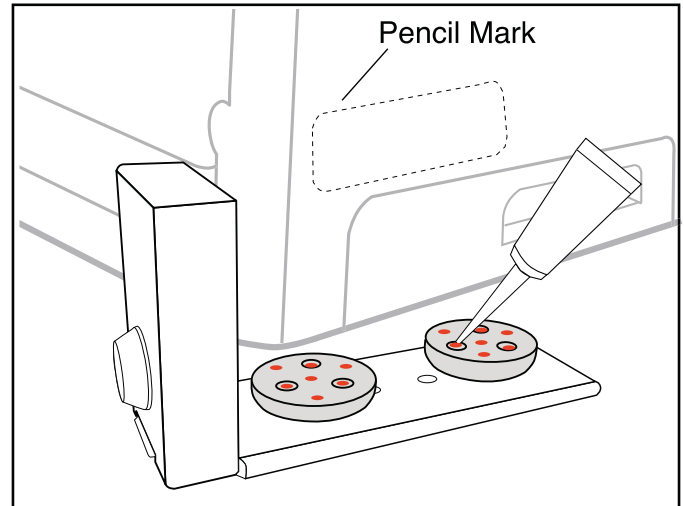

5. Quickly and carefully place the PTL in the marked area on the printer and apply **firm** and **steady** pressure for 100 seconds.

**After 100 seconds unlock & carefully remove the cover plate. Allow base plate to sit undisturbed for 24 hours.**

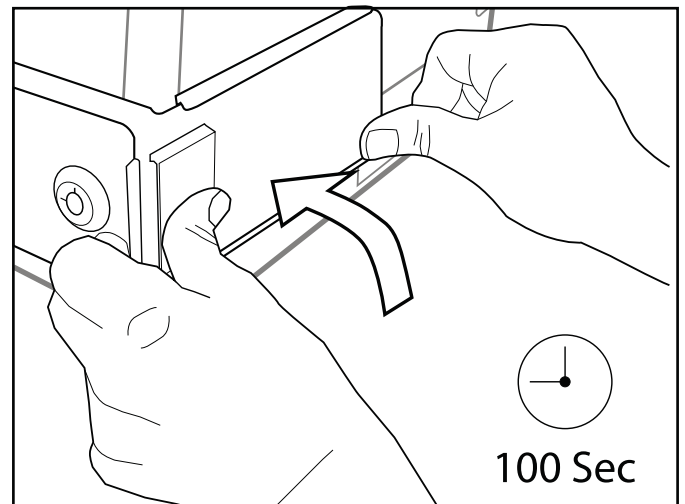

6. After 24 hours slide the cover plate onto the base plate and turn the key. For the combination lock turn the knob and scramble the code. Your printer is now secure!

\*Note - Retighten base plate screws if they were loosened during step 1. Do not overtighten screws. (Does not apply to PTL-3R/5R)

Combination #:  
(Combi Model Only)

